

REVISION RECORD				
REV	ECN	DESCRIPTION	DRFT	DATE

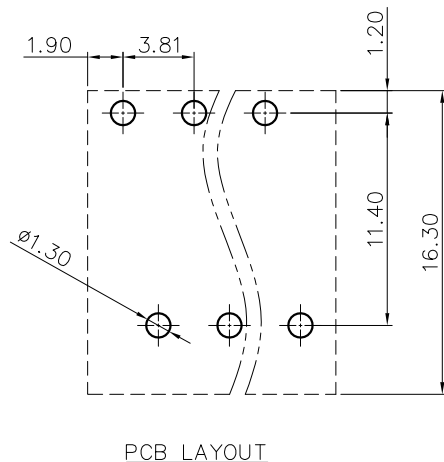
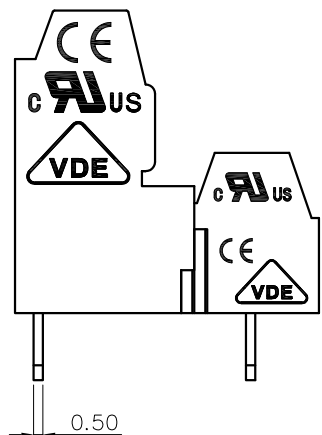
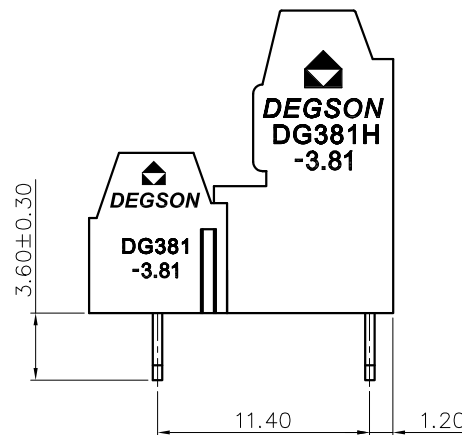
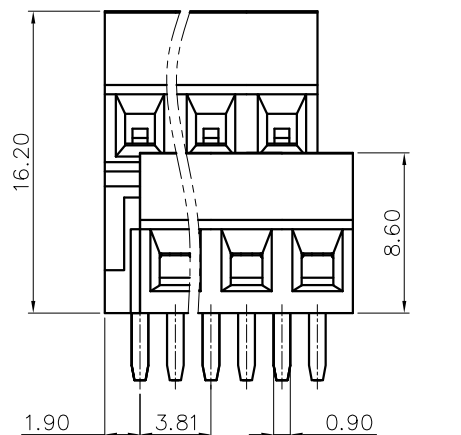
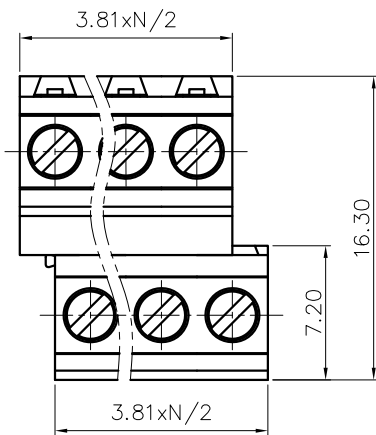

- NOTES1:
- UL Standard
 - 1.Rated Voltage/Current : 300V / 12A
 - 2.Torque Value : M2 , 1.77Lb.in
 - 3.Wire Range : 26~16AWG
- IEC Standard
- 1.Rated Voltage/Current : 130V / 10A
 - 2.Torque Value : M2 , 0.2N.m
 - 3.Wire Range : 0.2~1.0mm²
- NOTES2:
- 1.Dimension shall be interpreted per ASME Y14.5-2009
 - 2.Pitch : 3.5/3.81mm, Poles : N=04~XXP
 - 3.Stripping length : 5~6mm
 - 4.Withstanding Voltage : AC1250V/1Min.
 - 5.Operating temperature: -40°C~+105°C
 - 6.Undimensioned Tolerances:

Pitch range in mm		Nominal dimension range in mm				Tolerances		
TO	Over	TO	Over	TO	Over	TO	Over	
6	10	6	10	30	60	100	150	0.1/10
6	10	24	30	60	100	150	150	<
								±2'

7.RoHS Compliance

DG381A - 3.5/3.81 - XXP - 1Y - 00A (H)

(Series No.) (Pitch) (Poles) (Single Pitch) (RoHS) 00A-(Standard)

(Color):1.(Grey)2.(Blue)3.(Black)4.(Green)5.(Orange)6.(Red)7.(Transparent)8.(Yellow)9.(White)

DETACHED LISTS	PART NO.:	NINGBO DEGSON ELECTRICAL CO., LTD			
	APPD:	NAME: DG381A-3.5/3.81-XXP-1Y-00A(H)			
	CHKD:	TITLE: CUSTOMER DRAWING			
	DRFT:	DRAWING NO.:		REV	DO
THIRD ANGLE PROJECTION		DO NOT SCALE DRAWING		SHEET	1/1
		MM (INCH)	SCALE	1:1	