

Description

HKT4056E is a complete CC/CV linear charger for single cell lithium-ion batteries. It is specifically designed to work within USB power Specifications. No external sense resistor is needed and no blocking diode is required due to the internal P-MOSFET architecture. Thermal feedback regulates the charge current to limit the die temperature during high power operation or high ambient temperature. The charge voltage is fixed at 4.2V, and the charge current can be programmed externally with a single resistor. The HKT4056E automatically terminates the charge cycle when the charge current drops to 1/10th the programmed value after the final float voltage is reached. When the input supply (wall adapter or USB supply) is removed the HKT4056E automatically enters a low current state dropping the battery drain current to less than 1 μ A. The HKT4056E can be put into shutdown mode reducing the supply current to 70 μ A. Other features include Battery temperature monitor, under-voltage lockout, automatic recharge and two status pins to indicate charge and charge termination

Features

- Programmable Charge Current Up to 1A
- Preset 4.2V charge voltage with $\pm 1\%$ accuracy
- No MOSFET, Sense Resistor or blocking Diode Required
- Constant-Current/Constant-Voltage operation with Thermal Regulation to maximize Charge Rate Without Risk of overheating
- Charges Single Cell Li-Ion Batteries Directly from USB port
- Automatic recharge
- Battery Reverse Polarity Voltage Protection
- Charge Status Output Pin
Two Status Indication for Charge status
- C/10 Charge Termination
- 70 μ A Supply Current in Shutdown
- 2.9V Trickle Charge Threshold
- Soft-Start Limits Inrush Current
- Monitor output charge current
- Output with protection against anti-irrigation
- Battery Temperature Sensing
- Available Package: ESOP-8
- RoHS Compliant and Lead (Pb) Free

Application

- Cellular Telephones
- Charging Docks and Cradles
- Bluetooth Application
- Wearable Application

Typical Application Circuit

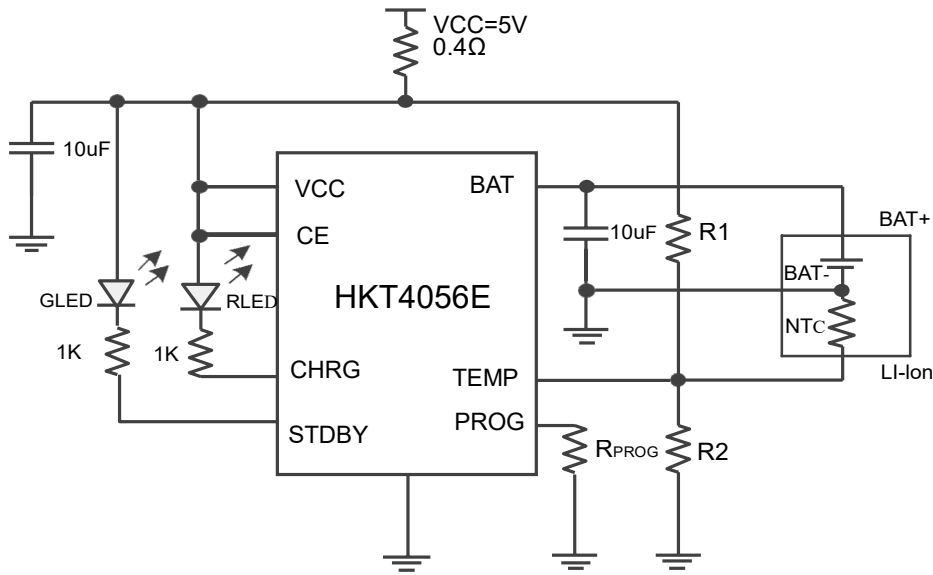

Pin Configuration (ESOP-8)

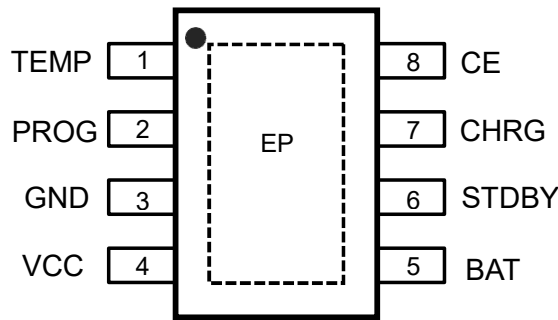

Pin Description

Pin	Name	Function
1	TEMP	Temperature sense input
2	PROG	Constant Charge Current Setting and Charge Current Monitor Pin
3	GND	Ground
4	VCC	Positive Input Supply Voltage Pin
5	BAT	Battery connection Pin
6	STDBY	Charge terminated status output
7	CHRG	Open-Drain Charge Status Output Pin
8	CE	Chip enable input

Order Information

Model	Marking	Description	Package	T/R Qty
HKT4056E	AiP4056	HKT4056E;1A;Standalone Linear Li-Ion Battery Charger; 2 Charge Status	ESOP-8	4,000 PCS

Absolute Maximum Ratings ^{(1) (2)}

Item	Min	Max	Unit
VCC Input Voltage	-0.3	7.0	V
PROG PIN Voltage	-0.3	VCC+0.3	V
BAT PIN Voltage	-0.3	7.0	V
CHRG、TEMP、STDBY、CE PIN Voltage	-0.3	7.0	V
Power dissipation	Internally Limited		
Operating Junction Temperature, T _J	-40	150	°C
Storage Temperature, T _{stg}	-65	125	°C
Operating Temperature Range	-40	85	°C
Lead Temperature (Soldering, 10sec.)		260	°C

Note (1): Exceeding these ratings may damage the device.

Note (2): The device is not guaranteed to function outside of its operating conditions.

ESD Ratings

Item	Description	Value	Unit
V(ESD-HBM)	Human Body Model (HBM) ANSI/ESDA/JEDEC JS-001-2014 Classification, Class: 2	±4000	V
V(ESD-CDM)	Charged Device Model (CDM) ANSI/ESDA/JEDEC JS-002-2014 Classification, Class: C0b	±400	V

Recommended Operating Conditions

Item	Min	Max	Unit
Operating junction temperature ⁽¹⁾	-40	125	°C
Operating temperature range	-40	85	°C

Note (1): All limits specified at room temperature (TA = 25°C) unless otherwise specified. All room temperature limits are 100% production tested. All limits at temperature extremes are ensured through correlation using standard Statistical Quality Control (SQC) methods. All limits are used to calculate Average Outgoing Quality Level (AOQL).

Thermal Information

Item	Description	Value	Unit
R _{θJA}	Junction-to-ambient thermal resistance ^{(1) (2)}	180	°C/W
R _{θJC(top)}	Junction-to-case (top) thermal resistance	130	°C/W
R _{θJB}	Junction-to-board thermal resistance	45	°C/W
ψ _{JT}	Junction-to-top characterization parameter	35	°C/W
ψ _{JB}	Junction-to-board characterization parameter	45	°C/W

Note (1): The package thermal impedance is calculated in accordance to JESD 51-7.

Note (2): Thermal Resistances were simulated on a 4-layer, JEDEC board.

Electrical Characteristics ^(Note)

$V_{CC} = 5V$, $T_A = 25^{\circ}C$, unless otherwise noted.

Parameter	Symbol	Test Conditions	Min	Typ.	Max	Unit
Input Supply Voltage	V_{CC}		4.5	5.0	7.0	V
Input Supply Current	I_{CC}	Charge Mode $R_{PROG} = 1.2k$		150	500	μA
		Standby Mode (Charge Terminated)		70	150	μA
		Shutdown Mode(R_{PROG} Not Connected), $V_{CC} < V_{BAT}$, or $V_{CC} < V_{UV}$		55	150	μA
Regulated Output (Float) Voltage	V_{FLOAT}	$0^{\circ}C \leq T_A \leq 85^{\circ}C$, $I_{BAT} = 40mA$	4.158	4.2	4.242	V
BAT Pin Current	I_{BAT}	$R_{PROG} = 2.4k$, Current Mode	450	500	550	mA
		$R_{PROG} = 1.2k$, Current Mode	900	1000	1100	mA
		Standby Mode, $V_{BAT} = 4.2V$	0	-5	-20	μA
		Sleep Mode, $V_{CC} = 0V$		1	2	μA
		ShutdownMode(R_{PROG} Not Connected)		0.7		μA
Trickle charge Current	I_{TRIKL}	$V_{BAT} < V_{TRIKL}$, $R_{PROG} = 2.4k$	40	55	60	mA
		$V_{BAT} < V_{TRIKL}$, $R_{PROG} = 1.2k$	80	100	120	mA
Trickle charge Threshold Voltage	V_{TRIKL}	$R_{PROG} = 1.2k$, V_{BAT} Rising	2.7	2.9	3.0	V
Trickle charge Hysteresis Voltage	V_{TRHYS}	$R_{PROG} = 1.2k$	60	80	100	mV
VCC Undervoltage Lockout Threshold	V_{UV}	From V_{CC} Low to High	3.7	3.8	3.95	V
VCC Undervoltage LockoutHysteresis	V_{UVHYS}		150	200	300	mV
Manual Shutdown Threshold Voltage	V_{MSD}	R_{PROG} Pin Rising	1.15	1.21	1.30	V
		R_{PROG} Pin Falling	0.9	1.0	1.1	V
$V_{CC} - V_{BAT}$ Lockout Threshold Voltage	V_{ASD}	V_{CC} from Low to High	70	100	140	mV
		V_{CC} from High to Low	5	30	50	mV
C/10 Termination Current Threshold	I_{TERM}	$R_{PROG} = 2.4k$	0.085	0.1	0.115	mA/mA
		$R_{PROG} = 1.2k$	0.085	0.1	0.115	mA/mA
PROG Pin Voltage	V_{PROG}	$R_{PROG} = 1.2k$, Current Mode	0.9	1.0	1.1	V
\overline{CHRG} Pin Weak Pull-Down Current	I_{CHRG}	$V_{CHRG} = 5V$	25	50	70	μA
\overline{CHRG} Pin Output Low Voltage	V_{CHRG}	$I_{CHRG} = 5mA$		0.35	0.6	V
Recharge battery threshold volatge protection	ΔV_{RECHRG}	$V_{FLOAT} - V_{RECHRG}$		50	100	mV
Thermal protection temperature	T_{LIM}			145		$^{\circ}C$

The voltage at TEMP increase	V_{TEMP-H}			80	85	%VCC	
The voltage at TEMP decrease	V_{TEMP-L}		40	45		%VCC	
The resistance of power FET "ON"	R_{ON}	Between VCC and BAT		650		m Ω	
RechargeComparator Filter Time	$t_{RECHARGE}$	V_{BAT} High to Low		0.8	1.8	4	mS
Termination comparator Filter Time	t_{TERM}	I_{BAT} Falling Below $I_{CHG}/10$		0.6	1.4	3	mS
Soft-Start Time	T_{SS}	$I_{BAT} = 0$ to $I_{BAT} = 1330V/R_{PROG}$		20			μ S
PROG Pin Pull-Up Current	I_{PROG}			2			μ A

Note : Absolute Maximum Ratings are those values beyond which the life of the device may be impaired. The HKT4056E is guaranteed to meet performance specifications from 0°C to 70°C. Specifications over the -40°C to 85°C operating temperature range are assured by design, characterization and correlation with statistical process controls. See Thermal Considerations.

Functional Block Diagram

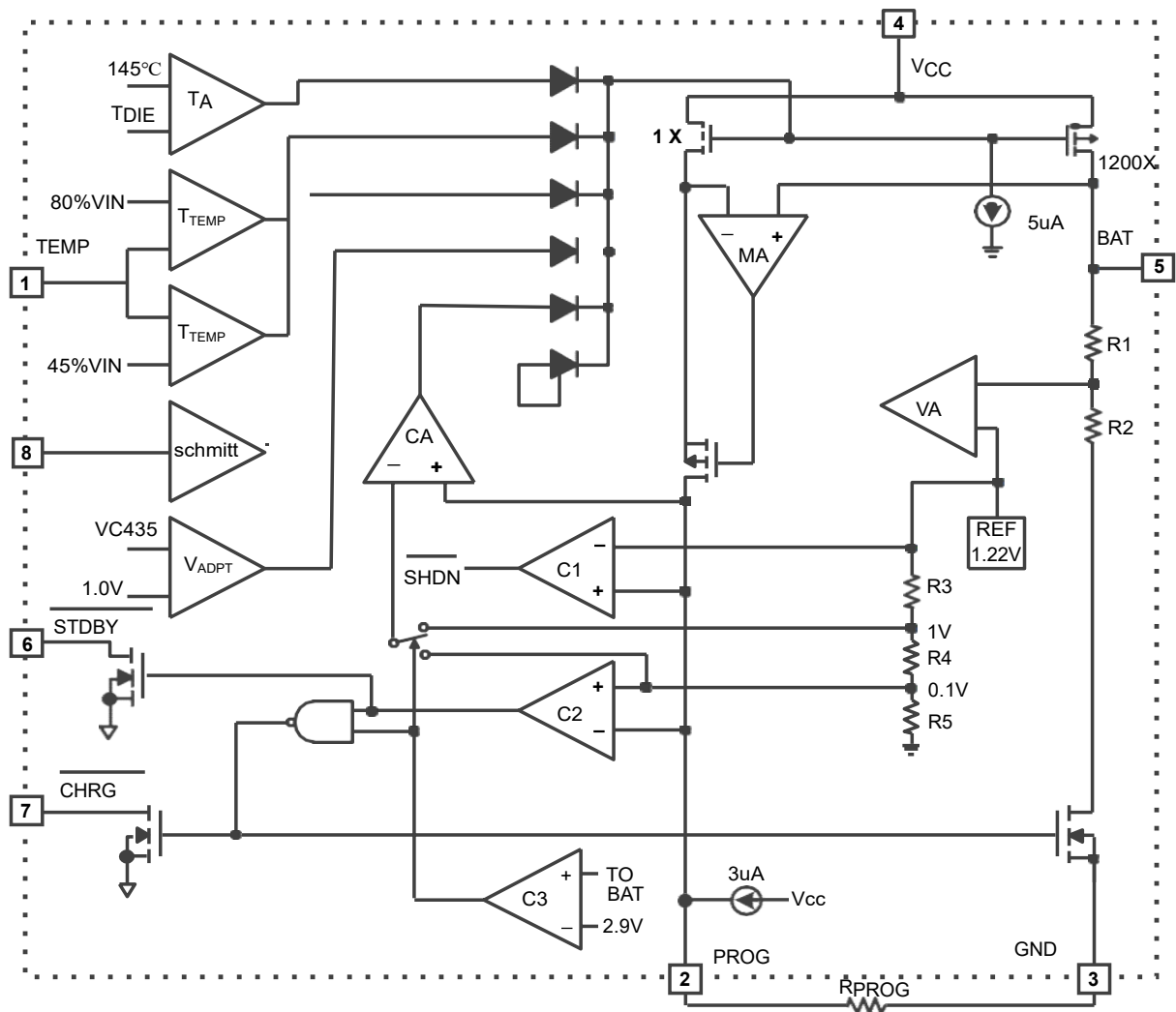

Functions Description

The HKT4056E is a complete CC/CV linear charger for single cell lithium-ion batteries. CC/CV to charger batter by internal MOSFET .It can deliver up to 1 A of charge current .No blocking diode or external current sense resistor is required. HKT4056E include two Open-Drain charge status Pins: Charge status indicator CHRG and battery failure status output STDBY.

The internal thermal regulation circuit reduces the programmed charge current if the die temperature attempts to rise above a preset value of approximately 145°C. This feature protects the HKT4056E from excessive temperature, and allows the user to push the limits of the power handling capability of a given circuit board without risk of damaging the HKT4056E or the external components. Another benefit of adopting thermal regulation is that charge current can be set according to typical, not worst-case, ambient temperatures for a given application with the assurance that the charger will automatically reduce the current in worst-case conditions.

The charge cycle begins when the voltage at the VCC pin rises above the UVLO level, a current set resistor is connected from the PROG pin to ground, and the CE pin is pulled above the chip enable threshold.The CHRG pin outputs a logic low to indicate that the charge cycle is on going. At the beginning of the charge cycle, if the battery voltage is below 2.9V, the charge is in precharge mode to bring the cell voltage up to a safe level for charging. The charger goes into the fast charge CC mode once the voltage on the BAT pin rises above 2.9 V. In CC mode, the charge current is set by RPROG. When the battery approaches the regulation voltage 4.2V, the charge current begins to decrease as the HKT4056E enters the CV mode. When the current drops to charge termination threshold, the charge cycle is terminated, and CHRG pin assumes a high impedance state to indicate that the charge cycle is terminated and STDBY pin is pulled low.The charge termination threshold is 10% of the current in CC mode. To restart the charge cycle, remove the input voltage and reapply it, or momentarily force CE pin to 0V. The charge cycle can also be automatically restarted if the BAT pin voltage falls below the recharge threshold. The on-chip reference voltage, error amplifier and the resistor divider provide regulation voltage with 1% accuracy which can meet the requirement of lithium-ion and lithium polymer batteries. When the input voltage is not present, or input voltage is below VBAT, the charger goes into a sleep mode, dropping battery drain current to less than 3 μ A. This greatly reduces the current drain on the battery and increases the standby time. The charger can be shutdown by forcing the CE pin to GND.

The charging profile is shown in the following figure:

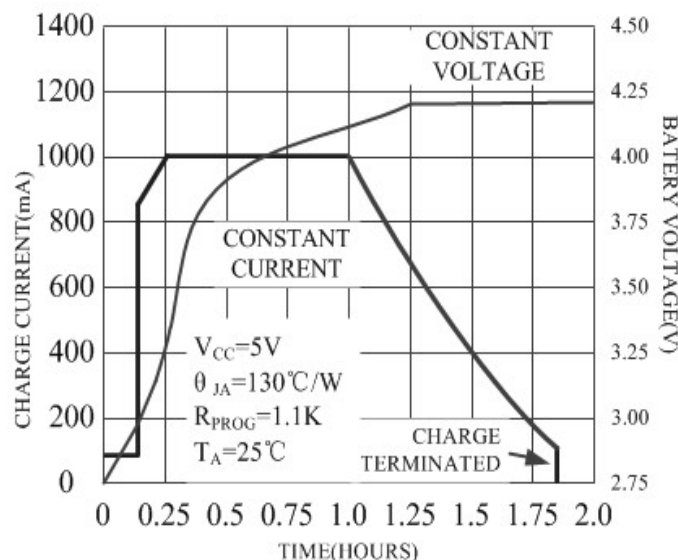

Programming Charge Current

The charge current is programmed using a single resistor from the PROG pin to ground. The battery charge current is 1200 times the current out of the PROG pin. The program resistor and the charge current are calculated using the following equations:

$$R_{PROG} = \frac{1200V}{I_{CHG}} \qquad I_{CHG} = \frac{1200V}{R_{PROG}}$$

The charge current out of the BAT pin can be determined at any time by monitoring the PROG pin voltage using the following equation:

$$I_{BAT} = \frac{V_{PROG}}{R_{PROG}} \times 1200$$

In application, according the charge current to determine RPROG ,the relation between RPROG and charge current can reference the following chart:

R _{PROG} (K)	I _{BAT} (mA)
12K	100
4K	300
2K	600
1.5K	800
1.2K	1000

Charge Termination

A charge cycle is terminated when the charge current falls to 1/10th the programmed value after the final float voltage is reached. This condition is detected by using an internal filtered comparator to monitor the PROG pin. When the PROG pin voltage falls below 100mV for longer than t_{TEMP} (typically 1.8mS), Charging is terminated. The charge current is latched off and the HKT4056E enters standby mode, where the input supply current drops to 35µA (Note:C/10 termination is disabled in trickle charging and thermal limiting modes).

When charging, transient loads on the BAT pin can cause the PROG pin to fall below 100mV for short periods of time before the DC charge current has dropped to 1/10th the programmed value. The 1.8mS filter time (t_{TEMP}) on the termination comparator ensures that transient loads of this nature do not result in premature charge cycle termination. Once the average charge current drops below 1/10th the programmed value, the HKT4056E terminated the charge cycle and ceases to provide any current through the BAT pin. In this state all loads on the BAT pin must be supplied by the battery.

The HKT4056E constantly monitors the BAT pin voltage in standby mode. If this voltage drops below the 4.10V recharge threshold (V_{RECHRG}), another charge cycle begins and current is once again supplied to the battery. To manually restart a charge cycle when in standby mode, the input voltage must be removed and reapplied or the charger must be shut down and restarted using the PROG pin. Figure 1 shows the state diagram of a typical charge cycle

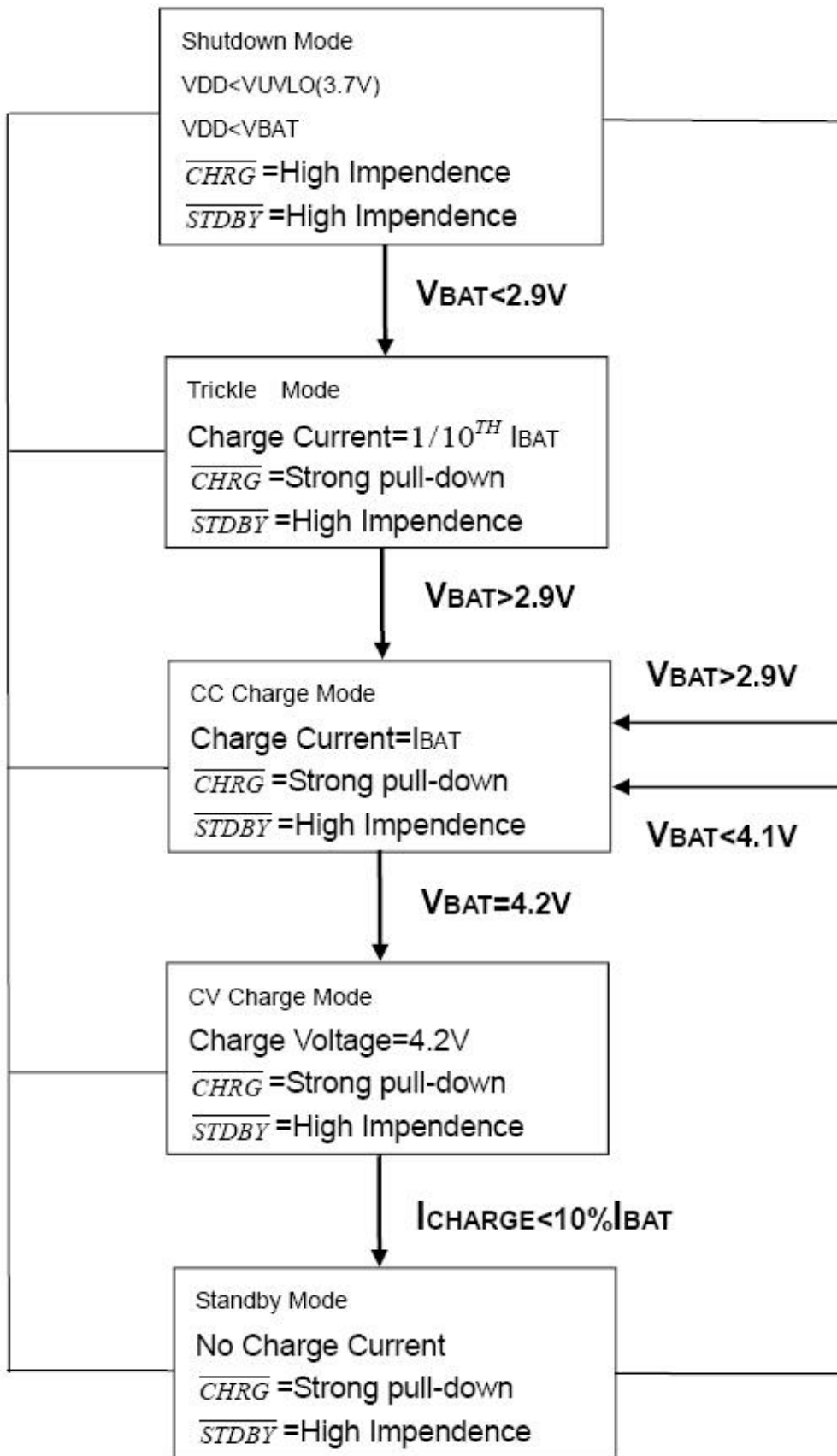

Figure :State diagram of a typical charge cycle

Charge status indicator

HKT4056E has two open-drain status indicator output CHRG and STDBY . CHRG is pull-down when the HKT4056E in a charge cycle. In other status CHRG in high impedance, CHRG and STDBY are all in high impedance when the battery out of the normal temperature.

Represent in failure state, when TEMP pin in typical connecting, or the charger with no battery: red LED and green LED all don't light. The battery temperature sense function is disabled by connecting TEMP pin to GND. If battery is not connected to charger, CHRG pin outputs a PWM level to indicate no battery. If BAT pin connects a 10μF capacitor, the frequency of CHRG flicker about 1-4S, If not use status indicator should set status indicator output connected to GND.

Charger's Status	Red led CHRG	Green led STDBY
Charging	light	dark
Battery in full state	dark	light
Under-voltage, battery's temperature is to high or too low, or not connect to battery(use TEMP)	dark	dark
BAT pin is connected to 10uF capacitor, No battery mode (TEMP=GND)	Green LED bright, Red LED flicker F=1-4 S	

Thermal limiting

An internal thermal feedback loop reduces the programmed charge current if the die temperature attempts to rise above a preset value of approximately 145°C . The feature protects the HKT4056E from excessive temperature and allows the user to push the limits of the power handling capability of a given circuit board without risk of damaging the HKT4056E. The charge current can be set according to typical (not worst-case) ambient temperature with the assurance that the charger will automatically reduce the current in worst-case conditions.

To prevent the damage caused by the very high or very low temperature done to the battery pack, the HKT4056E continuously senses battery pack temperature by measuring the voltage at TEMP pin determined by the voltage divider circuit and the battery's internal NTC thermistor.

The HKT4056E compares the voltage at TEMP pin (V_{TEMP}) against its internal V_{LOW} and V_{HIGH} thresholds to determine if charging is allowed. In HKT4056E, V_{LOW} is fixed at (45%× V_{CC}), while V_{HIGH} is fixed at (80%× V_{CC}). If $V_{TEMP} < V_{LOW}$ or $V_{TEMP} > V_{HIGH}$, it indicates that the battery temperature is too high or too low and the charge cycle is suspended. When V_{TEMP} is between V_{LOW} and V_{HIGH} , charge cycle resumes. The battery temperature sense function can be disabled by connecting TEMP pin to GND.

Selecting R1 and R2

The values of R1 and R2 in the application circuit can be determined according to the assumed temperature monitor range and thermistor's values. The Follows is an example: Assume temperature monitor range is $T_L \sim T_H$, ($T_L < T_H$); the thermistor in battery has negative temperature coefficient (NTC), R_{TL} is thermistor's resistance at T_L , R_{TH} is the resistance at T_H , so $R_{TL} > R_{TH}$, then at temperature T_H , the voltage at TEMP pin is:

$$V_{TEMPH} = \frac{R_2 || R_{TH}}{R_1 + R_2 || R_{TH}} \times V_{IN}$$

At temperature TL, the voltage at TEMP pin is:

$$V_{TEMPH} = \frac{R_2 || R_{TH}}{R_1 + R_2 || R_{TH}} \times V_{IN}$$

We know $V_{TEMPH} = V_{HIGH} = K_2 \times V_{CC}$ ($K_2=0.8$); $V_{TEMPH} = V_{LOW} = K_1 \times V_{CC}$ ($K_1=0.45$) Then we can have:

$$R_1 = \frac{R_{TL}R_{TH}(K_2 - K_1)}{(R_{TL} - R_{TH})K_1 K_2} \quad R_2 = \frac{R_{TL}R_{TH}(K_2 - K_1)}{R_{TL}(K_1 - K_1K_2) - R_{TH}(K_2 - K_1K_2)}$$

Likewise, for positive temperature coefficient thermistor in battery, we have $R_{TH} > R_{TL}$ and we can calculate:

$$R_1 = \frac{R_{TL}R_{TH}(K_2 - K_1)}{(R_{TH} - R_{TL})K_1 K_2} \quad R_2 = \frac{R_{TL}R_{TH}(K_2 - K_1)}{R_{TH}(K_1 - K_1K_2) - R_{TL}(K_2 - K_1K_2)}$$

We can conclude that temperature monitor range is independent of power supply voltage VCC and it only depends on R1, R2, RTL and RTH: The values of RTH and RTL can be found in related battery handbook or deduced from testing data. In actual application, if only one terminal temperature is concerned (normally protecting overheating), there is no need to use R2 but R1. It becomes very simple to calculate R1 in this case.

Under Voltage lockout (UVLO)

An internal under voltage lockout circuit monitors the input voltage and keeps the charger in shutdown mode until VCC rises above the under voltage lockout threshold . If the UVLO comparator is tripped, the charger will not come out of shutdown mode until VCC rises 140mV above the battery voltage

Manual terminate

At any time of the cycle of charging will put the HKT4056E into disable mode to pull CE pin to GND, or remove RPROG (PROG pin is float) . This made the battery drain current to less than 1μA and reducing the supply current to 35μA. To restart the charge cycle, set CE pin in high level or connect a programming resistor.

If HKT4056E in the under voltage Lockout mode, the CHRГ and STDBY are all in high impedance state, or VCC is above BAT pin 140mV, or VCC is too low.

Auto restart

Once charge is been terminated, HKT4056E immediately use a 1.8ms filter time ($t_{RECHARGE}$) on the termination comparator to constant monitor the voltage on BAT pin. If this voltage drops below the 4 .1V recharge threshold (about between 80% and 90% of VCC), another charge cycle begins. This ensured the battery maintained (or approach) to a charge full status and avoid the requirement of restarting the periodic charging cycle. In the recharge cycle, CHRГ pin enters a pulled down status.

Stability Considerations

In CC mode, the PROG pin is in the feedback loop, not the battery. The CC mode stability is affected by the impedance at the PROG pin. With no additional capacitance on the PROG pin, the charger is stable with program resistor values as high as 20K. However, additional capacitance on this node reduces the

maximum allowed program resistor. Therefore, if I_{PROG} pin is loaded with a capacitance C, the following equation should be used to calculate the maximum resistance value for R_{PROG}:

$$R_{PROG} \leq \frac{1}{2\pi \times 10^5 \times C_{PROG}}$$

As user, may think charge current is important, not instantaneous current. For example, to run a low current mode switch power which parallel connected with battery, the average current from BAT pin usually importance to instantaneous current. In this case, In order to measure average charge current or isolate capacitive load from I_{PROG} pin, a simple RC filter can be used on PROG pin as shown in Figure In order to ensure the stability add a 10K resistor between PROG pin and filter capacitor.

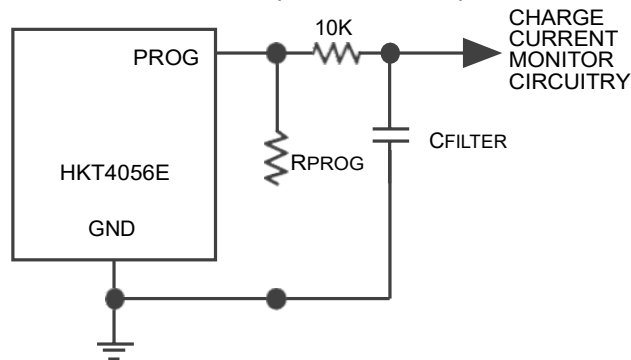

Figure : Isolating with capacitive load on PROG Pin

Power Dissipation

The conditions that cause the HKT4056E to reduce charge current through thermal feedback can be approximated by considering the power dissipated in the IC. Nearly all of this power dissipation is generated by the internal MOSFET-this is calculated to be approximately: $P_D = (V_{CC} - V_{BAT}) \times I_{BAT}$
The approximate ambient temperature at which the thermal feedback begins to protect the IC is:

$$T_A = 145^\circ\text{C} - P_D \times \theta_{JA} \quad ; \quad SO: \quad T_A = 145^\circ\text{C} - (V_{CC} - V_{BAT}) \times I_{BAT} \times \theta_{JA}$$

For example: The HKT4056E with 5V supply voltage through programmable provides full limiting current 850mA to a charge lithium-ion battery with 3.85V voltage. If J_A is 100°C/W (reference to PCB layout considerations), When HKT4056E begins to decrease the charge current, the ambient temperature about:

$$T_A = 145^\circ\text{C} - (5 - 3.85) \times 0.85 \times 100 = 47.25^\circ\text{C}$$

HKT4056E can work in the condition of the temperature is above 47.25°C, but the charge current will pull down to below 850mA. In a fixed ambient temperature, the charge current is calculated to be approximately :

$$I_{BAT} = \frac{145^\circ\text{C} - T_A}{(V_{CC} - V_{BAT}) \times \theta_{JA}}$$

Just as Description of the Principle part talks about so, the current on PROG pin will reduce in proportion to the reduced charge current through thermal feedback. In HKT4056E design applications don't need to considerate the worst case of thermal condition, this point is importance, because if the junction temperature up to 145°C ,HKT4056E will auto reduce the power dissipation.

Thermal Considerations

Because of the small size of the thin ESOP-8 package, it is important to use a good thermal PC board layout to maximize the available charge current. The PC board copper is the heat sink. The footprint copper pads should be as wide as possible and expand out to larger copper areas to spread and dissipate the heat to the surrounding ambient. Other heat sources on the board, not related to the charger, must also be considered when designing a PC board layout because they will affect overall temperature rise and the maximum charge current.

Add thermal regulation current

It will effective to decrease the power dissipation through reduce the voltage of both ends of the inner MOSFET. In the thermal regulation, this action of transporting current to battery will raise. One of the measure is through an external component(as a resistor or diode) to consume some power dissipation. For example: The HKT4056E with 5V supply voltage through programmable provides full limiting current 1000mA to a charge lithium-ion battery with 3.8V voltage. If JA is 120°C/W, so that at 25°C ambient temperature, the charge current is calculated to be approximately :

$$I_{BAT} = \frac{145^{\circ}\text{C} - 25^{\circ}\text{C}}{(V_{CC} - I_{BAT} \times R_{CC} - V_{BAT}) \times \theta_{JA}}$$

In order to increase the thermal regulation charge current, can decrease the power dissipation of the IC through reducing the voltage (as show fig.3) of both two ends of the resistor which connecting in series with a 5V AC adapter. With square equation to calculate I_{BAT}:

$$I_{BAT} = \frac{V_{CC} - V_{BAT} - \sqrt{(V_{CC} - V_{BAT})^2 - \frac{4R_{CC} \times (145^{\circ}\text{C} - T_A)}{\theta_{JA}}}}{2R_{CC}}$$

If R_{CC}=0.25Ω, V_{CC}=5V, V_{BAT}=3.75V, T_A=25 °C and J_A =120 °C/W, we can calculate the thermal regulation charge current: I_{BAT}=1080mA. It means that in this structure it can output 1000mA full limiting charge current at more high ambient temperature environment.

Although it can transport more energy and reduce the charge time in this application, but actually spread charge time, if HKT4056E stay in under-voltage state, when V_{CC} becomes too low in voltage mode. Figure shows how the voltage reduced with increase R_{cc} value in this circuit. This technique will act the best function when in order to maintain the minimize the dimension of the components and avoid voltage decreased to minimize R_{cc}.

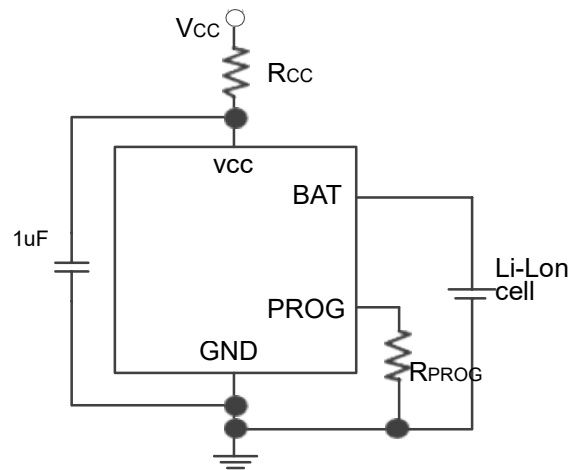
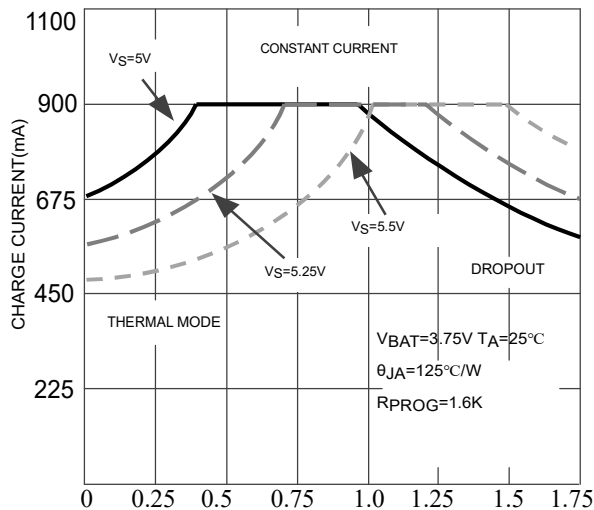

Figure: The Relationship Curve Between Charge Current With Rcc ; A Circuit To Maximum The Thermal Regulation Charge Current

VCC bypass capacitor

Many types of capacitors can be used for input bypassing, however, caution must be exercised when using multilayer ceramic capacitors. Because of the self-resonant and high Q characteristics of some types of ceramic capacitors, high voltage transients can be generated under some start-up conditions, such as connecting the charger input to a live power source. Adding a 1.5Ω resistor in series with a ceramic capacitor will minimize start-up voltage transients.

Charging Current Soft Start

HKT4056E includes a soft start circuit which used to maximize to reduce the surge current in the begging of charge cycle. When restart a new charge cycle, the charging current ramps up from 0 to the full charging current within 20μs. In the start process it can maximize to reduce the action which caused by surge current load.

USB and Wall Adapter Power

HKT4056E allows charging from a USB port, a wall adapter can also be used to charge Li-Ion/Li-polymer batteries. Figure 5 shows an example of how to combine wall adapter and USB power inputs. A P-channel MOSFET, Q1, is used to prevent back conducting into the USB port when a wall adapter is present and Schottky diode, D1, is used to prevent USB power loss through the 1KΩ pull-down resistor. Generally, AC adaptor is able to provide bigger much current than the value of specific current limiting which is 500mA for USB port. So can rise charge current to 600mA with using a N-MOSFET (Q1) and an additional set resistor value as high as 10K.

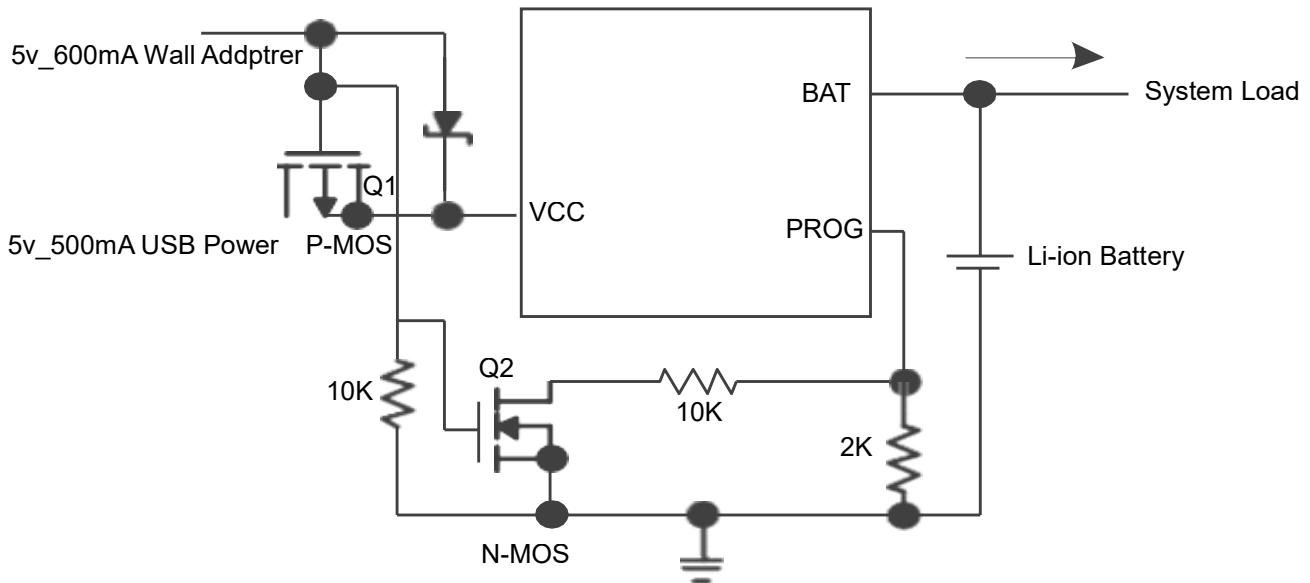

Figure:Combining Wall Adapter and USB Power

Board Layout Considerations

R_{PROG} at PROG pin should be as close to HKT4056E as possible, also the parasitic capacitance at PROG pin should be kept as small as possible. The capacitance at VCC pin and BAT pin should be as close to HKT4056E as possible. During charging, HKT4056E's temperature may be high, the NTC thermistor should be placed far enough to HKT4056E so that the thermistor can reflect the battery's temperature correctly.

It is very important to use a good thermal PC board layout to maximize charging current. The thermal path for the heat generated by the IC is from the die to the copper lead frame through the package lead (especially the ground lead) to the PC board copper, the PC board copper is the heat sink. The footprint copper pads should be as wide as possible and expand out to larger copper areas to spread and dissipate the heat to the surrounding ambient. Feed through vias to inner or backside copper layers are also useful in improving the overall thermal performance of the charger. Other heat sources on the board, not related to the charger, must also be considered when designing a PC board layout because they will affect overall temperature rise and the maximum charge current.

The ability to deliver maximum charge current under all conditions require that the exposed metal pad on the back side of the HKT4056E package be soldered to the PC board ground. Failure to make the thermal contact between the exposed pad on the backside of the package and the copper board will result in larger thermal resistance.

PACKAGE OUTLINE DRAWING FOR 8-SOIC w/ EXPOSED PAD

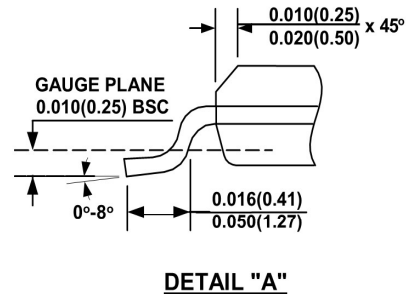
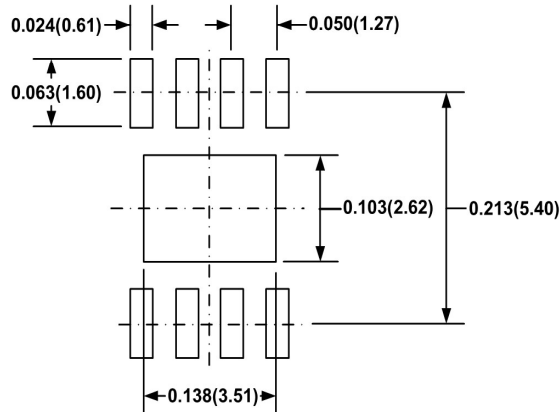
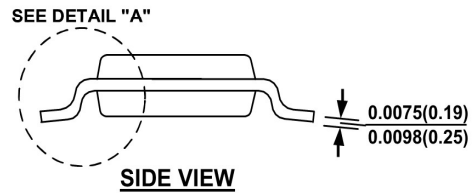
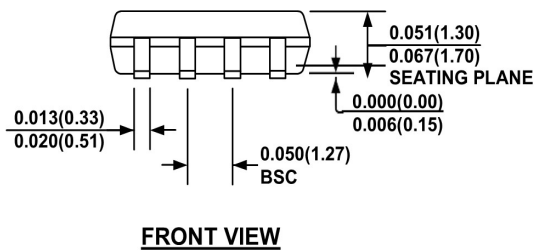
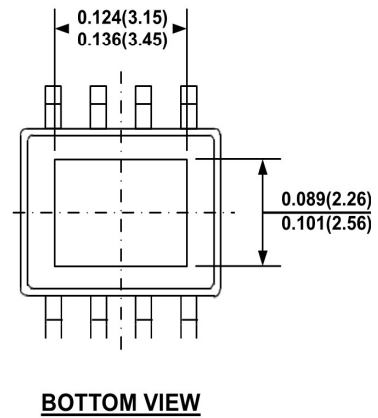
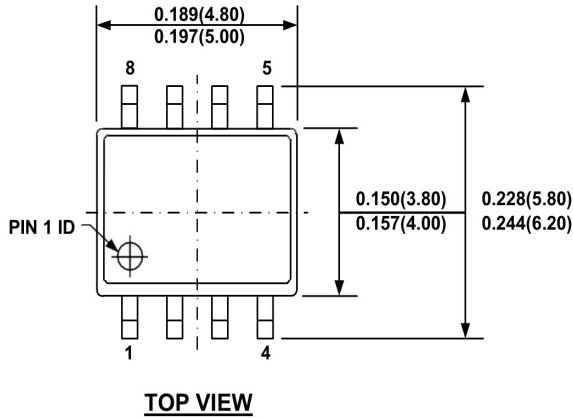

NOTE:

- 1) CONTROL DIMENSION IS IN INCHES. DIMENSION IN BRACKET IS IN MILLIMETERS.
- 2) PACKAGE LENGTH DOES NOT INCLUDE MOLD FLASH, PROTRUSIONS OR GATE BURRS.
- 3) PACKAGE WIDTH DOES NOT INCLUDE INTERLEAD FLASH OR PROTRUSIONS.
- 4) LEAD COPLANARITY (BOTTOM OF LEADS AFTER FORMING) SHALL BE 0.004" INCHES MAX.
- 5) DRAWING CONFORMS TO JEDEC MS-012, VARIATION BA.
- 6) DRAWING IS NOT TO SCALE.